

Boost Gauge Instructions



The following instructions are for the installation of your Boost Gauge into your 4th Generation Ram truck with a 6.7L Cummins Engine. Before you begin, lay out all items and ensure there are no missing parts. If any items are missing, please STOP immediately and contact MaxTow Gauges.

What's Included

- Boost Gauge
- 1/8-27 NPT Boost Pressure Sensor
- Power & Sensor Harnesses
- Mounting Bracket
- Gauge Visor

Wire Schematic

Yellow: 12v Constant Source (+)

Red: 12v Ignition Switched Source (+)

Orange: 12v Headlight Switched Source (+)

Black: Vehicle/Engine Ground (-)

⚠ WARNING Disconnect negative battery terminals before starting any work on the vehicle.

Check that you have all parts required for installation, and that the engine is cool.

Open the hood and locate the truck's batteries. Using a wrench, disconnect the negative terminal of each battery to ensure there is no power running through the truck during the installation.

Note: When it comes time to wire and connect the Gauge to its power source, you will be able to reconnect the negative terminals on the batteries.

The Boost Gauge can be installed by using a Boost Bolt Adapter that threads directly to the intake manifold horn and replaces the front inner intake heater grid bolt:

1. Remove the engine cover using an 8mm Socket.
2. Locate and remove the front inner intake heater grid bolt using a 10mm Socket with extension.
3. Attach the Boost Sensor to the Boost Bolt using 17mm and 22mm wrenches.
4. Install the Boost Bolt assembly using a 17mm Wrench and torque to 10 foot-pounds using a Torque Wrench.



5. Plug the sensor harness into the boost sensor and route up to the driver side of the engine bay firewall and use Zip Ties to secure the harness. Ensure there is no contact with any direct heat source or moving parts of the truck.
6. Reinstall the engine covering using an 8mm Socket.

Factory Matched 4th Gen Gauge Wiring

Reconnect the negative terminals of the two batteries to prepare power for the gauge and to test the fuses for power with a Test Light.

1. Run the power wires through the firewall and into the engine bay of the truck. **Note:** You may need to drill a hole in the firewall if there isn't one present. It is important to use a Grommet on the hole to ensure the wires are not sliced or cut on the firewall.
2. Drill a hole in the side of the fuse box located under the hood in order to run the wires inside without them being pinched on the fuse box lid. Be careful not to damage anything while drilling.

Note: Steps 3, 4, and 5 are based on a 2017 vehicle.

Please refer to the chart below for the fuse locations for your specific vehicle. Be sure that two fuses are installed in each optional Expandable Circuit. Expandable Circuits are available at MaxTow.com.

3. Locate and remove fuse #F84 ICS (15A) from the fuse panel. Using the Expandable Circuit, crimp the yellow wires to the Expandable Circuit and insert the circuit into the empty fuse #F84 ICS slot.
4. Locate and remove fuse #F93 CIGAR LIGHTER (20A) from the fuse panel. Using the Expandable Circuit, crimp the red wires to the Expandable Circuit and insert the circuit into the empty fuse #F93 slot.
5. Locate and remove fuse #F79 ID/CLEARANCE LT (15A) from the fuse panel. Using MaxTow's Expandable Circuit (Optional), crimp the orange wires to the Expandable Circuit and insert the circuit into the empty fuse #F79 slot.

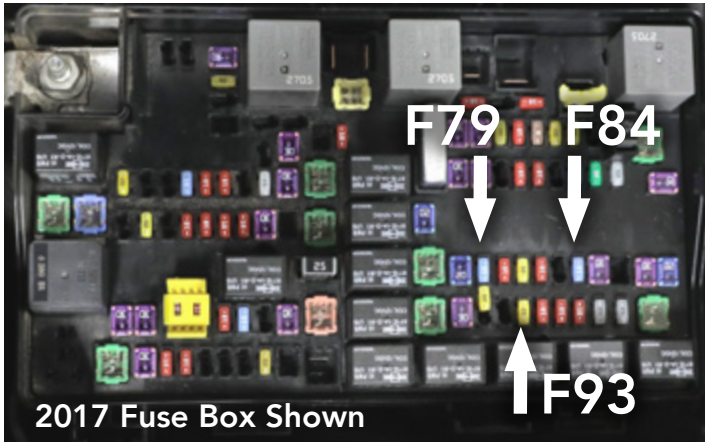

Selectable Brightness Levels

The Double Vision Gauge Series features 3 selectable brightness settings for both day and nighttime lighting modes. Below are the instructions on how to program each lighting mode.

Daytime

- Press and hold the button located on the gauge face until a "d1" appears in the digital display.
- Press the button again to cycle through the 3 dimming modes.
- Press the button until you have selected your desired setting. Do not touch the button for 5 seconds and the gauge will save your selection.

Nighttime

- This mode is only available if the orange dimmer wire is connected and your headlights are powered.
- Press and hold the button located on the gauge face until an "n1" appears in the digital display.
- Press the button again to cycle through the 3 dimming modes.
- Press the button until you have selected your desired setting. Do not touch the button for 5 seconds and the gauge will save your selection.

Universal Gauge Wiring

1. Using a test light, locate a constant 12-Volt Power Source in the vehicle's fuse panel that receives 12-Volt Power when the ignition is turned off. You can splice into the circuit or use an optional Expandable Circuit. Connect the **Yellow Wire** of the gauge to the Constant 12-Volt Power Source.

Note: It is required to use an automotive grade 18-20 gauge wire and proper splice connectors when extending any of the power wires.

2. Repeat the same step for the **Red Wire** of the gauge to locate an Ignition Switched 12-Volt Power Source. This source should not have any power with the key turned off and have 12-Volts with the key turned on.
3. Connect the **Orange Wire** of the gauge to the positive Headlight Switch Power Source using a Splice Connector at the headlight switch. You can also use an Expandable Circuit and install into the fuse box if you have a fuse available. This will allow the gauge face to dim 30% when the headlights are turned on.

Note: Make sure that the connection source does not dim. If the voltage is reduced when you lower the Dimmer Wheel it will cause the gauge to flash from not having enough voltage.

4. Locate a clean, reliable grounding source and connect the **Black Wire** from the gauge.

	Fuse #	Description	Fuse Size	Fuse Type
2010-2012				
Yellow Constant Wire	M27	Ignition Switch	20 Amp	Mini
Red Switched Wire	M6	Power Outlet 1	20 Amp	Mini
Orange Headlight Switched Wire	M35	Left Front & Rear Parklamps	15 Amp	Mini
2013-2018				
Yellow Constant Wire	F84	Switch Bank/ Instrument Cluster	15 Amp	Micro II
Red Switched Wire	F93	Cigar Lighter	20 Amp	Micro II
Orange Headlight Switched Wire	F79	Clearance Lights	15 Amp	Micro II

6. Connect the black wire to any bare metal grounding location. If the black wire is not connected to a bare metal grounding location the gauges will not power on.

Tip: Remove all rust and paint from the grounding location for a better connection.

7. Secure any excess wiring with Zip Ties.
8. Power the truck on to confirm the boost gauge is functioning properly and check for any leaks or loose sensor connections.
9. Test drive your vehicle to ensure the boost gauge is functioning properly.

Note: The Boost Gauge will only read while driving.

Additional Information

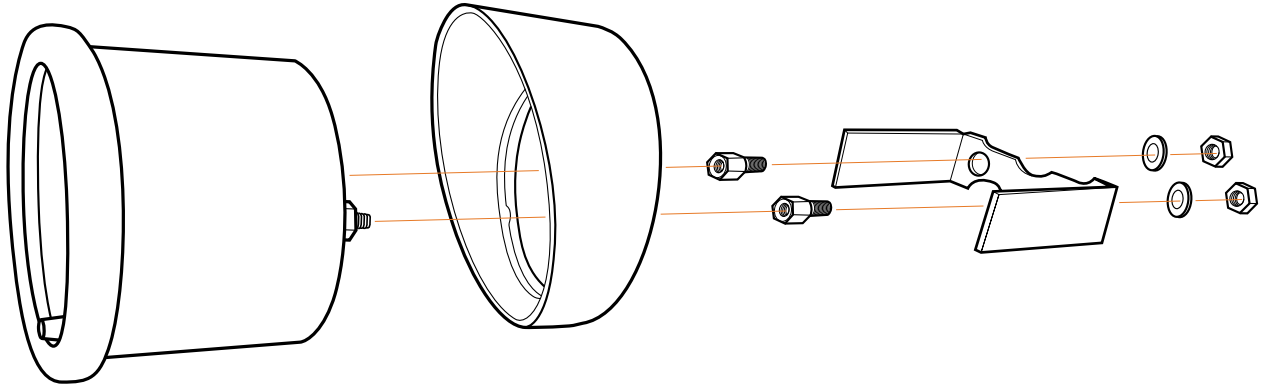

- The supplied optional gauge visor is intended to be placed on the gauge so that the thickest part is at the top, creating a cover over the gauge to help keep sun glare off of the gauge face.
- The included mounting bracket is designed to be used on a universal-style mount in order to keep the gauge secure. In some cases one or both legs of the bracket may need to be modified to fit the thickness and contour of the mount. Our A-pillar gauge pods do not require the use of the mounting bracket but can be used if you desire, and there is enough space to fit it between the gauge and the gauge pod. When installing the bracket onto the gauge, make sure not to over-tighten as it could pull the rear studs on the back of the gauge and damage it.
- MaxTow Gauges Installation Instructions: Installation documents are solely to provide a guide for individuals that are mechanically and electronically able to install products. If you are unsure about the correct procedure of installation for a product, you should consult a licensed professional.



ONE YEAR NON-TRANSFERRABLE LIMITED WARRANTY & DISCLAIMER

MaxTow Gauges, LLC ("MaxTow") warrants to the original retail consumer purchaser, and not any other purchaser or subsequent owner, that this Product will be free from defects in material or workmanship for a period of **one (1) year** from the purchase date.

For a period of **one (1) year** from the date of purchase, at no charge to the Purchaser, MaxTow will repair or replace this Product if it is determined by MaxTow to be defective. After the warranty period, the Purchaser must pay all charges for parts and labor.

Coverage under this warranty is only valid within the United States, including its territories, as well as in certain other countries. Purchasers should check our website, www.MaxTow.com, to determine the warranty coverage in the countries in which they are located.

MaxTow does **not warrant the installation** of the Product, which is the sole responsibility of the Purchaser. Installation should be done by licensed professionals. Improper installation may cause damage to the Product and any vehicle in which it is installed, and may cause burns and electrical injury to individuals. MaxTow's warranty does not cover any expenses incurred in removing Products that are defective or reinstalling replacement Products in their place.

During the warranty period, to have the Product repaired or replaced, the Purchaser must return the Product, freight prepaid by the Purchaser, to MaxTow (but for customers in the contiguous United States, MaxTow will pay the shipping charges if any Product fails during the first thirty (30) days after purchase). The Product must be returned in its original carton or in a similar package affording an equal degree of protection. MaxTow will return the repaired or replaced Product, freight prepaid, to the Purchaser. MaxTow does not provide Purchasers with temporary replacement units during the warranty period or at any other time.

This limited warranty is nontransferable and will automatically terminate if the original retail consumer purchaser resells the Product or transfers the vehicle in which the Product is installed. An "original retail consumer purchaser" is a person who originally purchases the Product, or a gift recipient of a new Product that is in its original packaging and unopened.

This limited warranty is subject to all of the following terms and conditions:

TERMS & CONDITIONS

- 1. NOTIFICATION OF CLAIMS; WARRANTY SERVICE:** If Purchaser believes that a Product is defective in material or workmanship, written notice with an explanation of the claim shall be given promptly by Purchaser to MaxTow. All warranty claims must be made within the warranty period, and any Products returned to MaxTow must be shipped in accordance with MaxTow's procedures (including use of RMA numbers supplied by MaxTow after notification). The repair or replacement of any Product or part thereof shall not extend the original warranty period. The specific warranty on the repaired part only (not including gauge sensors) shall be in effect for a period of ninety (90) days following the repair or replacement of that part, or the remaining period of the Product warranty, whichever is greater. MaxTow does not provide a warranty on replacement gauge sensors.
- 2. EXCLUSIVE REMEDY; ACCEPTANCE:** Purchaser's exclusive remedy and MaxTow's sole obligation is to supply (or pay for) all labor necessary to repair any Product found to be defective within the repair or replacement fails to remedy the defect. Purchaser's failure to make a claim as provided in paragraph 1 above or continued use of the Product shall constitute an unqualified acceptance of such Product and a waiver by Purchaser of all claims thereto.
- 3. EXCEPTIONS TO LIMITED WARRANTY:** MaxTow shall have no obligation to Purchaser with respect to any Product that is subjected to any of the following: abuse, improper use, negligence, accident, modification, failure to follow the operating procedures outlined in the user's manual, failure to follow the maintenance procedures in the service manual for the Product, attempted repair by nonqualified personnel, operation of the Product outside of the published environmental and electrical parameters, or if the Product's original identification (trademark, serial number) markings have been defaced, altered, or removed. MaxTow excludes from warranty coverage Products sold AS IS and/or WITH ALL FAULTS. MaxTow also excludes from warranty coverage any consumable items such as fuses and batteries.

All software and accompanying documentation furnished with, or as part of the Product is furnished "AS IS" (i.e., without any warranty of any kind), except where expressly provided otherwise in any documentation or license agreement furnished with the Product.

- 4. PROOF OF PURCHASE; REGISTRATION:** The Purchaser's dated bill of sale must be retained as evidence of the date of purchase and to establish warranty eligibility. Registration of any Product or of this limited warranty is voluntary, and failure to register will not diminish any rights available under this warranty.

DISCLAIMER OF WARRANTY

EXCEPT FOR THE FOREGOING WARRANTIES, MAXTOW HEREBY DISCLAIMS AND EXCLUDES ALL OTHER WARRANTIES, EXPRESS OR IMPLIED, INCLUDING, BUT NOT LIMITED TO ANY IMPLIED WARRANTIES OF MERCHANTABILITY, FITNESS FOR A PARTICULAR PURPOSE, OR ANY WARRANTY WITH REGARD TO ANY CLAIM OF INFRINGEMENT THAT MAY BE PROVIDED IN SECTION 2312(3) OF THE UNIFORM COMMERCIAL CODE OR IN ANY OTHER STATE STATUTE.

LIMITATION OF LIABILITY

THE LIABILITY OF MAXTOW, IF ANY, AND PURCHASER'S SOLE AND EXCLUSIVE REMEDY FOR DAMAGES FOR ANY CLAIM OF ANY KIND WHATSOEVER, REGARDLESS OF THE LEGAL THEORY AND WHETHER ARISING IN TORT OR CONTRACT, SHALL NOT BE GREATER THAN THE ACTUAL PURCHASE PRICE OF THE PRODUCT FOR WHICH SUCH CLAIM IS MADE. IN NO EVENT SHALL MAXTOW BE LIABLE TO PURCHASER FOR ANY SPECIAL, INDIRECT, INCIDENTAL, OR CONSEQUENTIAL DAMAGES OF ANY KIND INCLUDING, BUT NOT LIMITED TO, COMPENSATION, REIMBURSEMENT OR DAMAGES ON ACCOUNT OF THE LOSS OF PRESENT OR PROSPECTIVE PROFITS OR FOR ANY OTHER REASON WHATSOEVER.

GOVERNING LAW: This nontransferable limited warranty shall be governed by the law of the State of New Jersey, U.S.A., and the United States of America, excluding their conflicts of laws principles. The courts of Camden County, New Jersey, shall have the exclusive jurisdiction over any legal action with respect to this warranty.

This limited warranty gives specific legal rights. You may also have other rights that may vary from state to state or from country to country. Some states or countries do not allow the exclusion or limitation of incidental or consequential damages, so the above limitations and exclusions may not apply to you. You are advised to consult applicable state or country laws for a full determination of rights.