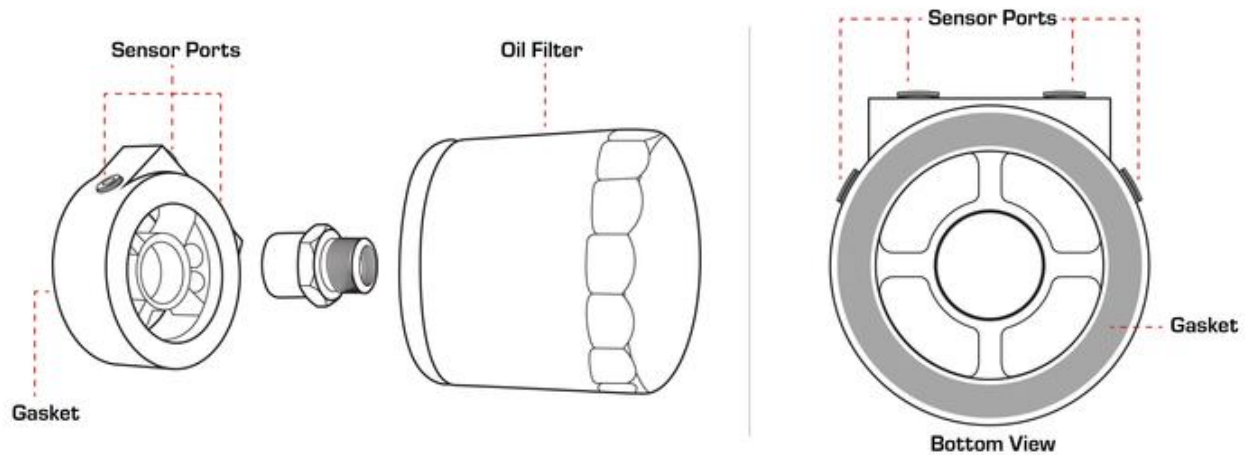

**GM Duramax Oil Filter Sandwich Adapter**

This GM Duramax Oil Filter Sandwich Adapter is designed for spin-on oil filters with a max gasket outer diameter of 4 inches and a minimum inner diameter of 3 inches.

1. **OPTIONAL STEP** Raise the vehicle using a jack and support it using jack stands.
2. Remove your vehicle's oil filter and make sure there is enough clearance for the oil filter sandwich adapter.
3. Install your gauge's temperature or pressure sensors to one of the 1/8<sup>th</sup> NPT ports located on the adapter. Install all necessary oil feed lines, sensors or any other port plugs at this time using Teflon tape on all of the threads to ensure no leaks will occur.
4. Install the Oil Filter Sandwich Adapter to the threads where the oil filter is usually mounted lubricating the O-ring with oil.
  - Do not overtighten the sandwich adapter. If it is overtightened, the gasket that seals it could tear and result in oil leaks. It should be a little more than hand-tight, similar to an oil filter.
5. Install a new oil filter to the threads on the sandwich plate adapter; be sure to lubricate the O-ring with oil.
6. Once the sandwich adapter is installed with the sensors attached, finish installing your gauge as per the included instructions.
7. Start the engine to check the sandwich adapter and oil filter for any leaks.

All GlowShift Products are subject to the GlowShift Limited Warranty. Please visit <https://www.glowshiftdirect.com/warranty-policies> to review complete Warranty, Terms, and Conditions.