

Banjo Bolt Adapter Installation for**1998.5-2007 Dodge Ram with the 5.9L 24-Valve Cummins Diesel with a VP44 or CP3 Pump**

1989-1993 Dodge Ram with the 5.9L 12-Valve Cummins Diesel with a VE Pump on reverse side

1. Remove your stock banjo bolt from the bottom of the fuel filter housing.

- Please make sure to remove the “old” crush washers from both sides of the fuel line.

2. Place the included crush washer on the new banjo bolt adapter and place the fuel line onto the adapter. After the fuel line is connected to the banjo bolt, place the second included crush washer onto the banjo bolt adapter to ensure the fuel line is properly secured and no fuel leaks occur.

3. Thread the banjo bolt adapter into the bottom of the fuel filter housing.
 - Torque the banjo bolt to 18 ft. lbs using a 19mm wrench.

4. Install your fuel pressure sensor into the snubber valve, which in-turn is installed into the female end of the banjo bolt adapter.
 - Be sure to use Teflon tape on the snubber valve threads to ensure a tight seal.

5. Cycle the key 6 times to prime the fuel system.

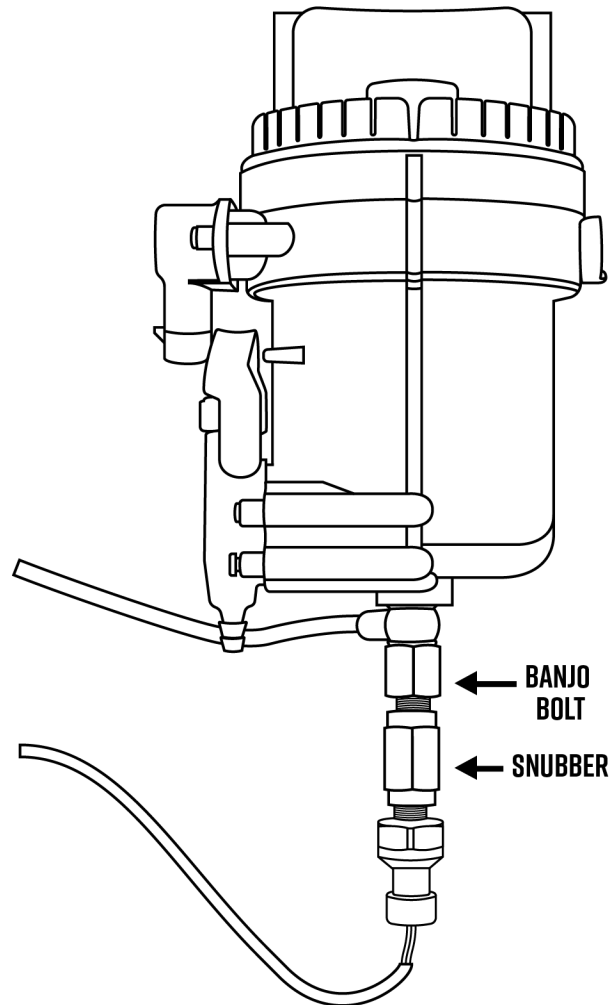

We recommend installing a snubber valve with the banjo bolt adapter. The snubber valve regulates, normalizes and eliminates fuel pressure spikes that are present during the primary ignition and startup of your Dodge Ram with a Cummins Diesel Engine. These high pressure spikes are managed by absorbing damaging pulsations and surges, while keeping accurate data flowing to ensure your gauge is performing at optimal levels. High pressure fuel system spikes during startup are harmful and may cause early and unexpected failure of electronic fuel pressure sensors and/or sending units for fuel pressure gauges.

All GlowShift Products are subject to the GlowShift Limited Warranty. Please visit <https://www.glowshiftdirect.com/warranty-policies> to review complete Warranty, Terms, and Conditions.

Banjo Bolt Adapter Installation for**1989-1993 Dodge Ram with the 5.9L 12-Valve Cummins Diesel with a VE Pump**

1998.5-2007 Dodge Ram with the 5.9L 24-Valve Cummins Diesel with a VP44 or CP3 Pump on reverse side

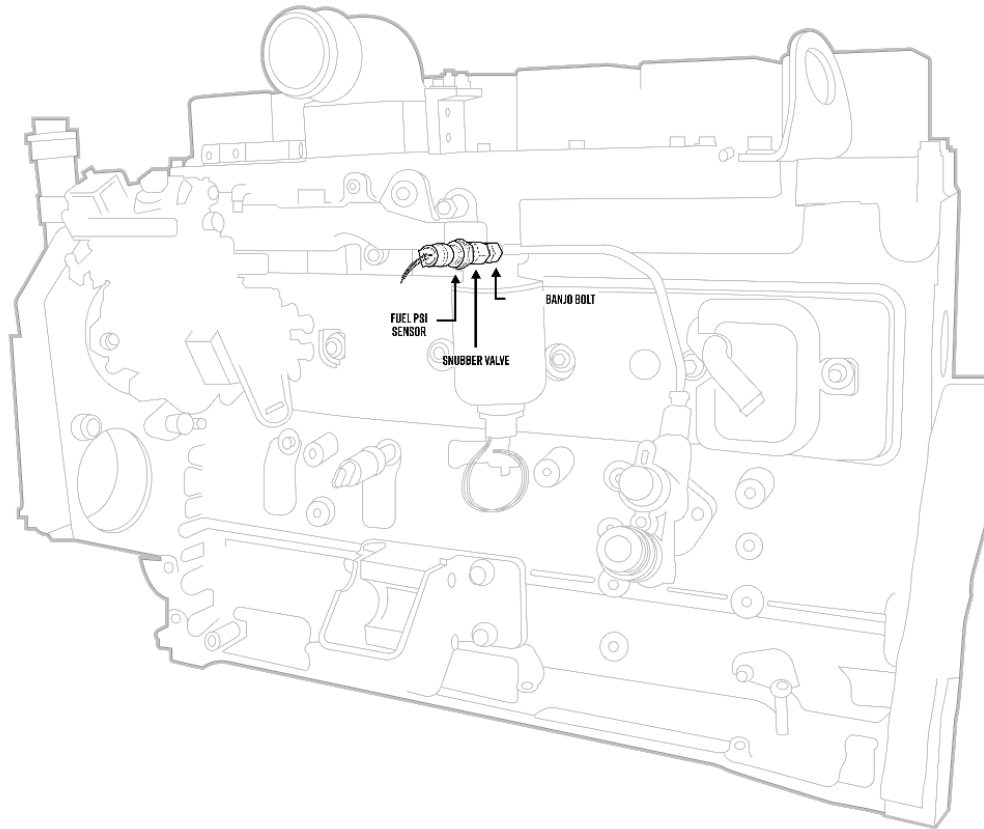

1. Remove your stock banjo bolt from the fuel line that is feeding the fuel filter using a 17mm wrench.
 - Make sure to remove the “old” crush washers from both sides of the fuel line.
2. Place the included crush washer on the new banjo bolt adapter and place the fuel line onto the adapter. After the fuel line is connected to the banjo bolt, place the second included crush washer onto the banjo bolt adapter to ensure the fuel line is properly secured and that no fuel leaks occur.
3. Thread the banjo bolt adapter into the fuel filter housing fitting right above the filter.
 - Torque the banjo bolt to 18 ft. lbs using a 19mm wrench.
4. Install your fuel pressure sensor into the snubber valve, which in-turn is installed into the female end of the banjo bolt adapter.
 - Be sure to use Teflon tape on the snubber valve threads to ensure a tight seal.

We recommend installing a snubber valve with the banjo bolt adapter. The snubber valve regulates, normalizes and eliminates fuel pressure spikes that are present during the primary ignition and startup of your Dodge Ram with a Cummins Diesel Engine. These high pressure spikes are managed by absorbing damaging pulsations and surges, while keeping accurate data flowing to ensure your gauge is performing at optimal levels. High pressure fuel system spikes during startup are harmful and may cause early and unexpected failure of electronic fuel pressure sensors and/or sending units for fuel pressure gauges.

All GlowShift Products are subject to the GlowShift Limited Warranty. Please visit <https://www.glowshiftdirect.com/warranty-policies> to review complete Warranty, Terms, and Conditions.