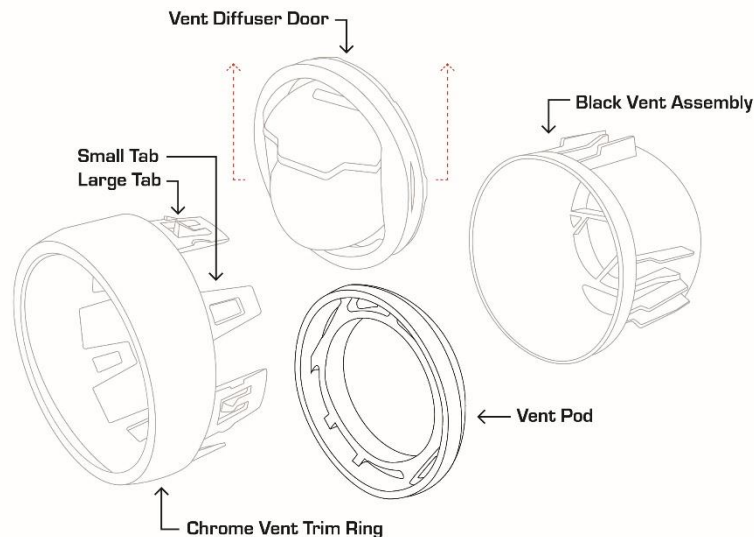

Vent Gauge Pod for 2015-2020 Ford Mustang

1. Carefully remove the dash trim to the right of the glove box first followed by the dash trim going across the dash above the glove box by releasing the spring clips with a panel pop tool.
2. Once removed, press on the large Chrome tabs from the vent trim ring and remove the vent assembly from the dash trim.
3. Using a panel pop tool, carefully lift the small Chrome tabs from the vent trim ring and remove from the black vent assembly.
4. Place the vent diffuser door off to the side and store away as it will no longer be used.
5. Place the vent pod gauge ring in the black vent assembly and reinstall the vent trim ring.
Note: You will notice that the thin profile of the chrome vent trim ring should line up with the flat section of the vent assembly for everything to secure properly.
6. With the vent assembly back together, temporarily slide the gauge in and test-fit the clearance inside the vent assembly. It may be necessary to trim the honeycomb on the black vent assembly in order for the gauge and wiring to fit properly.
7. Once you have confirmed that there is enough clearance, slide the gauge into the vent pod.
Note: The vent pod is designed to hold the gauge in place, if your gauge is loose or if you want to secure it, install the studs on the back of the gauge and secure with the supplied gauge bracket. Be sure **NOT TO OVERTIGHTEN** the nuts on the back of the gauge.
8. Slide the vent assembly back into the dash trim and clip into location.
Note: The flat section of the vent assembly will be at the bottom.
9. Before reinstalling the dash trim into the vehicle, route the power and sensor wires over to the passenger foot well. The power and ground connections can be made at the fuse box area behind the passenger kick panel. If your sensor harness has to be ran through the firewall from the engine bay into the vehicle, there is a grommet you can pass through if you remove the passenger front wheel well liner that will gain access under the dash.
10. Route those wires from the passenger foot well area under the dash to behind the radio and secure with zip ties. In some cases it is easier to remove the radio in order to help feed the wires to the vent location. Using a step bit, drill a hole through the vent duct work large enough to pass the connectors through.
11. Connect the power and sensor wires to the back of the gauge and secure the dash trim back onto the dash board. Reinstall the radio if it was removed along with the dash trim to the right of the glove box.
12. Finish installing the gauge following the gauge instructions.

All GlowShift Products are subject to the GlowShift Limited Warranty. Please visit <https://www.glowshiftdirect.com/warranty-policies> to review complete Warranty, Terms, and Conditions.