

7 Color Fuel Rail Pressure Gauge



The following instructions are for the installation of your Fuel Rail Pressure Gauge. Before you begin, lay out all items and ensure there are no missing parts. If any items are missing, please STOP immediately and contact GlowShift Gauges.

What's Included

- Fuel Rail Pressure Gauge
- Power & Sensor Harnesses
- Mounting Bracket
- Gauge Visor

Wire Schematic

Yellow: 12v Constant Source (+)

Red: 12v Ignition Switched Source (+)

Orange: 12v Headlight Switched Source (+)

Black: Vehicle/Engine Ground (-)

⚠️ WARNING Disconnect negative battery terminals before starting any work on the vehicle.

1. Plug the Fuel Rail Pressure Sensor Harness into the back of the gauge.

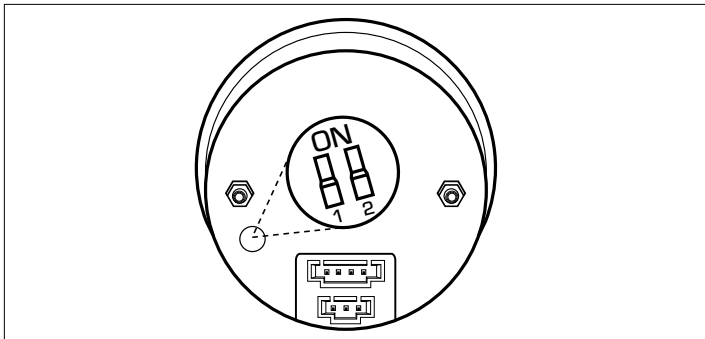

2. Route the Fuel Rail Pressure Sensor Harness through the engine bay and firewall using a grommet, keeping it clear of any moving parts and heat sources.

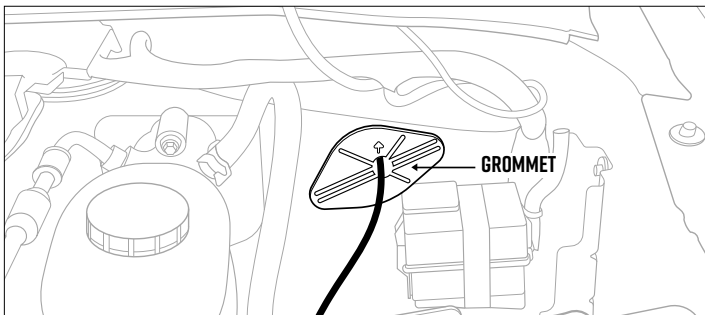

3. Connect the gauge sensor harness to your factory rail PSI sensor signal wire. This sensor is usually located on the common rail towards the firewall. Please refer to your repair manual for the exact location of this sensor. Refer to chart to the right for the color of your vehicle's factory sensor wire and programming switch locations. Splice the **Green Signal Wire** and **Black Ground Wire** from the gauge to the factory Fuel Rail Pressure Sensor Harness.

Optional: To make the installation easier, there is an available inline pigtail harness for some models on www.GlowShift.com. Simply unplug your 3 wire Fuel Rail Pressure Harness from the sensor and connect GlowShift's Fuel Rail Pressure Gauge Wiring Harness allowing you to keep your factory wiring intact. Once all of the connections are made splice the 2 pigtail wires to the gauge harness, **Green to Green** and **Black to Black**.

Fitment Chart

Duramax	Signal Wire	Ground Wire	Switch Position
02-05, 07-08, 12-14, 16 (6.6)	Yellow	Orange/Black	Both Switches in UP position
06, 09-11 (6.6)	Orange/Black	White	Both Switches in DOWN position
15 (6.6)	Blue/Green	Black	Both Switches in DOWN position
17-19 (6.6)	Blue/White	Black/Green	Both Switches in DOWN position
Cummins	Signal Wire	Ground Wire	Switch Position
03 (5.9)	Pink/Black	Violet/Red	Both Switches in UP position
04-07 (5.9)	Brown/Yellow	Brown/White	Both Switches in UP position
07-12 (6.7)	Brown/Yellow	Brown/Orange	Both Switches in DOWN position
13-18 (6.7)	Brown/Yellow	Dark Blue/ Pink	Both Switches in UP position
19 (6.7)	Brown/Yellow	Dark Blue/ Black	Both Switches in UP position
Powerstroke	Signal Wire	Ground Wire	Switch Position
08-10 (6.4)	Blue/Brown Pin 39 on PCM	Green/White Pin 9 on PCM	Both Switches in DOWN position

Gauge Wiring

1. In order to test for power, reconnect the Negative Battery Terminal.
2. It may be necessary to remove the Vehicle Trim and/or Kick Panels in order to gain access to the vehicle's Fuse Box.
3. Plug the Fuel Rail Pressure Power Harness into the back of the gauge.
4. Route the Fuel Rail Pressure Power Harness to the fuse box, using a grommet if necessary, keeping it clear of any moving parts and heat sources.
5. Using a test light, locate a constant 12-Volt power source in the vehicle's fuse panel that receives 12- Volt power when the ignition is turned off. You can splice into the circuit or use an optional Expandable Circuit. Connect the **Yellow Wire** of the gauge to the Constant 12-Volt Power Source.
6. Repeat the same step for the **Red Wire** of the gauge to locate an Ignition Switched 12-Volt Power Source. This source should not have any power with the key turned off and have 12 Volts with the key turned on.
7. Connect the **Orange Wire** of the gauge to the positive Headlight Switch Power Source using a Splice Connector, either in the fuse box or at the switch itself.

Note: Make sure the connection source does not dim. If the voltage is reduced when you lower the Dimmer Wheel it will cause the gauges to flicker from not having enough voltage.

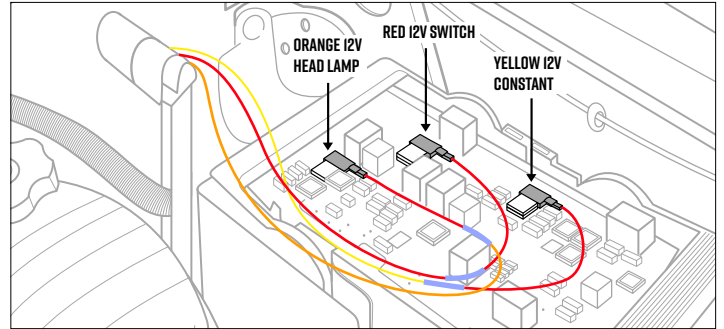

8. Locate a clean, reliable grounding source and connect the **Black Wire** from the gauge.
9. After all wiring is complete, turn the vehicle's key to the "On" position and confirm that your gauge illuminates.
10. Press the **COLOR** Changing Button on your gauge and scroll through the 7 Color options as well as the Color Change and Color Fade option: this will allow you to have the Gauge Face change between all of the colors automatically.
11. Turn on the headlights to ensure that the gauge is dimming.
12. Reinstall any panels that may have been removed.
13. Ensure your gauge is functioning properly.

Additional Information

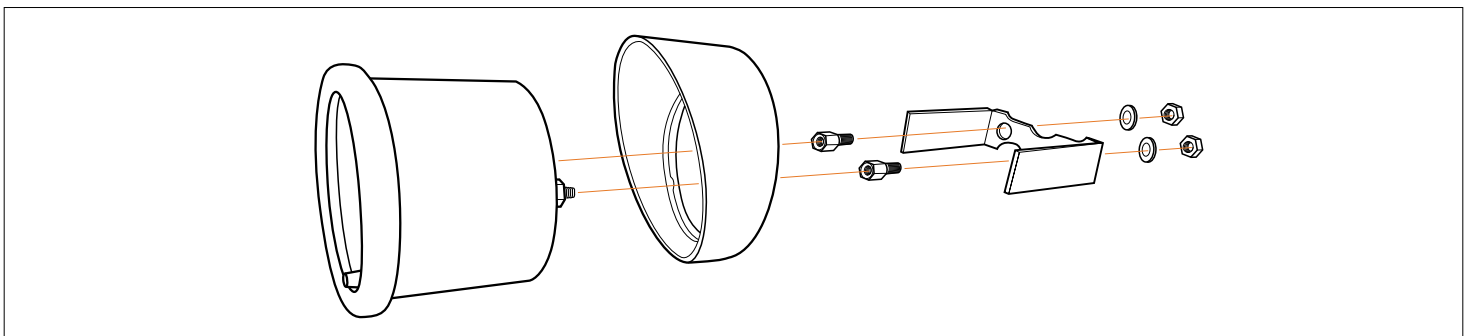

- The supplied optional gauge visor is intended to be placed on the gauge so that the thickest part is at the top, creating a cover over the gauge to help keep sun glare off of the gauge face.
- The included mounting bracket is designed to be used on a universal-style mount in order to keep the gauge secure. In some cases one or both legs of the bracket may need to be modified to fit the thickness and contour of the mount. Our A-pillar gauge pods do not require the use of the mounting bracket but can be used if you desire, and there is enough space to fit it between the gauge and the gauge pod. When installing the bracket onto the gauge, make sure not to over-tighten as it could pull the rear studs on the back of the gauge and damage it.
- GlowShift Gauges Installation Instructions: Installation documents are solely to provide a guide for individuals that are mechanically and electronically able to install products. If you are unsure about the correct procedure for the installation of a product, you should consult a licensed professional.



ONE YEAR NON-TRANSFERRABLE LIMITED WARRANTY & DISCLAIMER

GlowShift Gauges, LLC ("GlowShift") warrants to the original retail consumer purchaser, and not any other purchaser or subsequent owner, that this Product will be free from defects in material or workmanship for a period of **one (1) year** from the purchase date.

For a period of **one (1) year** from the date of purchase, at no charge to the Purchaser, GlowShift will repair or replace this Product if it is determined by GlowShift to be defective. After the warranty period, the Purchaser must pay all charges for parts and labor.

Coverage under this warranty is only valid within the United States, including its territories, as well as in certain other countries. Purchasers should check our website, www.GlowShift.com, to determine the warranty coverage in the countries in which they are located.

GlowShift does **not warrant the installation** of the Product, which is the sole responsibility of the Purchaser. Installation should be done by licensed professionals. Improper installation may cause damage to the Product and any vehicle in which it is installed, and may cause burns and electrical injury to individuals. GlowShift's warranty does not cover any expenses incurred in removing Products that are defective or reinstalling replacement Products in their place.

During the warranty period, to have the Product repaired or replaced, the Purchaser must return the Product, freight prepaid by the Purchaser, to GlowShift (but for customers in the contiguous United States, GlowShift will pay the shipping charges if any Product fails during the first thirty (30) days after purchase). The Product must be returned in its original carton or in a similar package affording an equal degree of protection. GlowShift will return the repaired or replaced Product, freight prepaid, to the Purchaser. GlowShift does not provide Purchasers with temporary replacement units during the warranty period or at any other time.

This limited warranty is nontransferable and will automatically terminate if the original retail consumer purchaser resells the Product or transfers the vehicle in which the Product is installed. An "original retail consumer purchaser" is a person who originally purchases the Product, or a gift recipient of a new Product that is in its original packaging and unopened.

This limited warranty is subject to all of the following terms and conditions:

TERMS & CONDITIONS

- 1. NOTIFICATION OF CLAIMS; WARRANTY SERVICE:** If Purchaser believes that a Product is defective in material or workmanship, written notice with an explanation of the claim shall be given promptly by Purchaser to GlowShift. All warranty claims must be made within the warranty period, and any Products returned to GlowShift must be shipped in accordance with GlowShift's procedures (including use of RMA numbers supplied by GlowShift after notification). The repair or replacement of any Product or part thereof shall not extend the original warranty period. The specific warranty on the repaired part only (not including gauge sensors) shall be in effect for a period of ninety (90) days following the repair or replacement of that part, or the remaining period of the Product warranty, whichever is greater. GlowShift does not provide a warranty on replacement gauge sensors.
- 2. EXCLUSIVE REMEDY; ACCEPTANCE:** Purchaser's exclusive remedy and GlowShift's sole obligation is to supply (or pay for) all labor necessary to repair any Product found to be defective within the repair or replacement fails to remedy the defect. Purchaser's failure to make a claim as provided in paragraph 1 above or continued use of the Product shall constitute an unqualified acceptance of such Product and a waiver by Purchaser of all claims thereto.
- 3. EXCEPTIONS TO LIMITED WARRANTY:** GlowShift shall have no obligation to Purchaser with respect to any Product that is subjected to any of the following: abuse, improper use, negligence, accident, modification, failure to follow the operating procedures outlined in the user's manual, failure to follow the maintenance procedures in the service manual for the Product, attempted repair by nonqualified personnel, operation of the Product outside of the published environmental and electrical parameters, or if the Product's original identification (trademark, serial number) markings have been defaced, altered, or removed. GlowShift excludes from warranty coverage Products sold AS IS and/or WITH ALL FAULTS. GlowShift also excludes from warranty coverage any consumable items such as fuses and batteries.

All software and accompanying documentation furnished with, or as part of the Product is furnished "AS IS" (i.e., without any warranty of any kind), except where expressly provided otherwise in any documentation or license agreement furnished with the Product.

- 4. PROOF OF PURCHASE; REGISTRATION:** The Purchaser's dated bill of sale must be retained as evidence of the date of purchase and to establish warranty eligibility. Registration of any Product or of this limited warranty is voluntary, and failure to register will not diminish any rights available under this warranty.

DISCLAIMER OF WARRANTY

EXCEPT FOR THE FOREGOING WARRANTIES, GLOWSHIFT HEREBY DISCLAIMS AND EXCLUDES ALL OTHER WARRANTIES, EXPRESS OR IMPLIED, INCLUDING, BUT NOT LIMITED TO ANY IMPLIED WARRANTIES OF MERCHANTABILITY, FITNESS FOR A PARTICULAR PURPOSE, OR ANY WARRANTY WITH REGARD TO ANY CLAIM OF INFRINGEMENT THAT MAY BE PROVIDED IN SECTION 2312(3) OF THE UNIFORM COMMERCIAL CODE OR IN ANY OTHER STATE STATUTE.

LIMITATION OF LIABILITY

THE LIABILITY OF GLOWSHIFT, IF ANY, AND PURCHASER'S SOLE AND EXCLUSIVE REMEDY FOR DAMAGES FOR ANY CLAIM OF ANY KIND WHATSOEVER, REGARDLESS OF THE LEGAL THEORY AND WHETHER ARISING IN TORT OR CONTRACT, SHALL NOT BE GREATER THAN THE ACTUAL PURCHASE PRICE OF THE PRODUCT FOR WHICH SUCH CLAIM IS MADE. IN NO EVENT SHALL GLOWSHIFT BE LIABLE TO PURCHASER FOR ANY SPECIAL, INDIRECT, INCIDENTAL, OR CONSEQUENTIAL DAMAGES OF ANY KIND INCLUDING, BUT NOT LIMITED TO, COMPENSATION, REIMBURSEMENT OR DAMAGES ON ACCOUNT OF THE LOSS OF PRESENT OR PROSPECTIVE PROFITS OR FOR ANY OTHER REASON WHATSOEVER.

GOVERNING LAW: This nontransferable limited warranty shall be governed by the law of the State of New Jersey, U.S.A., and the United States of America, excluding their conflicts of laws principles. The courts of Camden County, New Jersey, shall have the exclusive jurisdiction over any legal action with respect to this warranty.

This limited warranty gives specific legal rights. You may also have other rights that may vary from state to state or from country to country. Some states or countries do not allow the exclusion or limitation of incidental or consequential damages, so the above limitations and exclusions may not apply to you. You are advised to consult applicable state or country laws for a full determination of rights.