

Tinted Series Wideband Air/Fuel Ratio Gauge

For Product Numbers: GS-T02W

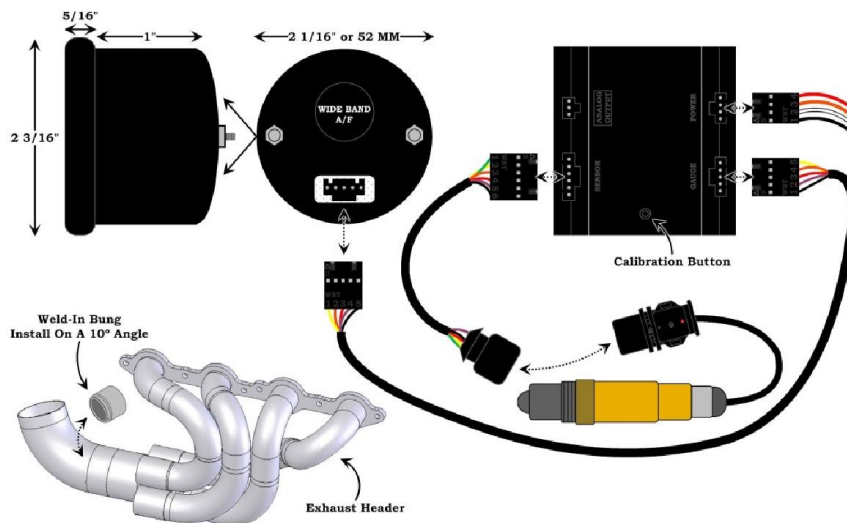

Wire Harness Color Code

Red: 12v Constant Source (+) (un-switched)	Black: Vehicle Ground (-)
White: 12v Ignition Source (+) (switched)	Orange: 12v Switched Headlamp Source (+) (optional)

1. Disconnect the negative battery cable.
2. Mount the controller inside the vehicle away from heat, water, moisture, dirt and all moving parts, in an easily accessible location. This allows for the unit to be accessible should calibration need to be performed.
3. Install the provided LSU 4.9 Sensor by welding the matching exhaust bung to the exhaust pipe.
 - **Note: We recommend using Anti-Seize on the bung threads so that you can unscrew the sensor when necessary.**
 - **Make sure the location of the bung is no less than a minimum of 6 inches after the exhaust ports, but before the catalytic converter, and no more than 36 inches from the last exhaust port.**
 - **The bung must be installed to the top or side of the exhaust pipe at a minimum of 10 degrees for the top and 15 degrees for the side from a horizontal position with the electrical connection up to prevent a collection of liquid at the element during the warm up phase.**
4. Next, route and secure the sensor wire harness from the sensor into the vehicle, close to the controller's location. Be sure to use a grommet when routing the wires through the firewall to protect them from stripping.
5. Connect the **red wire** to a positive 12 volt **constant (un-switched)** source either directly to the battery or to a fuse panel on the vehicle. If wiring to an un-fused source, install a 3 amp fuse inline within 20 inches of the sources connection.
6. The **white wire** should be connected to a positive 12 volt **ignition (switched)** source. It may be connected to the fuse panel, an accessory wire, or any positive 12 volt source that turns on and off with the ignition
7. Connect the **black wire** to any good (unpainted) ground connection. You may also route a wire directly to the negative side of the vehicle's battery.
8. The Night Time Dimming feature decreases the brightness of the gauge face by 30%. Connect the **orange wire** to the 12 volt positive headlamp source. This allows the mode to be activated when the headlights come on. This step is optional and will not affect operation of the gauge if it is omitted.
 - **Note: Do not connect the orange wire to a dimmer wheel. This will cause the gauge lighting to flicker.**
9. Reconnect the negative battery cable.

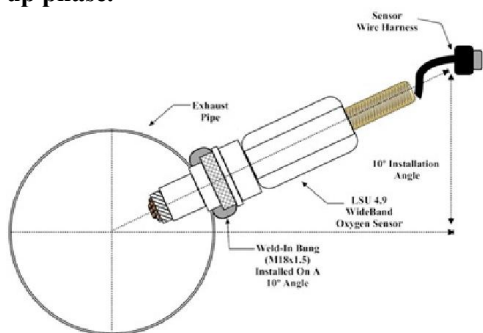

Calibration Schedule

Prior to calibration remove the sensor from the bung. This will ensure a proper calibration.

To obtain the most accurate results from your gauge, please follow the calibration schedule pre and post installation:

A. For Everyday Driven Vehicles

- Calibrate after installation.
- Calibrate again, after 3 months of use.
- Calibrate twice a year or every 10,000 miles (whichever comes first).

B. For Race Vehicles

- Calibrate after installation.
- Calibrate once per race weekend.

C. Dynamometer Use

- Calibrate after installation.
- Calibrate every 2-3 days, depending on the amount of usage.

Functions:

1. Prior to operation, the sensor must warm up for 30 seconds. This is a mandatory process every time the gauge and sensor are powered from a cold vehicle start. The LED display will show a scrolling graphic until the warm up phase is complete.
2. If necessary you may perform a manual calibration by pressing the button on the controller for 3 seconds, to initialize a controller /sensor calibration sequence. The LED display on the gauge will show a [2] until the calibrating process is over.
3. If the LED display on the gauge shows a [3] then there is a sensor error detected. Check and confirm the connection of the sensor and wire harness to and from the controller unit. If the connections are secure and in place, press the button on the controller for 8 seconds to reset the controller to the original factory settings. The LED display will show a [2] and then a [4]. After this the factory settings are programmed and restored to your controller. your display shows a [3] again, your sensor may be defective.

Digital Display: This gauge is equipped with a Digital A/F Ratio display with a range between 10 ~ 20 AFR. If the AFR is below 10 or higher than 20 for more than 3 seconds the display will flash.

AFR Quality	AFR Value
RICH:	10 ~ 12.9 AFR
OPTIMAL:	13 ~ 17.9 AFR
LEAN:	18 ~ 20 AFR

Additional Installation Information & Material Requirements

- **GlowShift Gauges Approved Conductor Wires:** Successfully installing GlowShift Gauges may require lengths of wire (sizes and quantity depend on vehicle, gauge type, gauge location and / or sensor location). For correct and proper GlowShift Gauge installation and operation, the use of 18 Gauge (wire diameter) automotive grade conductor wire with sheathing is recommended for one or more gauges per vehicle. When installing and routing wires from the engine compartment, to inside the vehicle cabin, always employ the use of a rubber grommet. This will prevent and deter the stripping of power supply and / or sensor wires that is necessary to deliver vital statistics about your engine to your GlowShift engine monitoring instruments. Never use wire nuts to fasten or bound vehicle / gauge or sensor wiring. Always use securing crimp connectors or solder individual wire junctions together for optimum gauge installation and operation.
- **GlowShift Gauges Approved Installation Accessories:** GlowShift Gauges may require the installer or user to provide additional products, accessories or adapters for the correct installation and operation of a gauge or sensor, as per the GlowShift Installation Instructions. When installing and routing hoses to or from the engine compartment, to inside the vehicle cabin, always employ the use of a rubber grommet. This will prevent and deter the stretching or pinching of hoses that is necessary to deliver vital statistics about your engine to your GlowShift engine monitoring instruments.
- **GlowShift Gauges Installation Instructions:** Installation documents are solely to provide a guide for individuals that are mechanically and electronically able to install products. If you are unsure about the correct procedure of installation for a product or device, you should consult a professional mechanic or an Authorized GlowShift Installer.



INSTALLATION INSTRUCTIONS

Tech Support
856-768-8300 EXT 2

TechSupport@GlowShiftGauges.com

ONE YEAR NON-TRANSFERRABLE LIMITED WARRANTY AND DISCLAIMER

GlowShift Gauges, LLC ("GlowShift") warrants to the original retail consumer purchaser, and not any other purchaser or subsequent owner, that this Product will be free from defects in material or workmanship for a period of **one (1) year** from the purchase date. For a period of **one (1) year** from the date of purchase, at no charge to the Purchaser, GlowShift will repair or replace this Product if it is determined by GlowShift to be defective. After the warranty period, the Purchaser must pay all charges for parts and labor. Coverage under this warranty is only valid within the United States, including its territories, as well as in certain other countries. Purchasers should check our website, www.GlowShift.com, to determine the warranty coverage in the countries in which they are located. GlowShift does **not warrant the installation** of the Product, which is the sole responsibility of the Purchaser. Installation should be done by licensed professionals. Improper installation may cause damage to the Product and any vehicle in which it is installed, and may cause burns and electrical injury to individuals. GlowShift's warranty does not cover any expenses incurred in removing Products that are defective or re-installing replacement Products in their place. During the warranty period, to have the Product repaired or replaced, the Purchaser must return the Product, freight prepaid by the Purchaser, to GlowShift (but for customers in the contiguous United States, GlowShift will pay the shipping charges if any Product fails during the first thirty (30) days after purchase). The Product must be returned in its original carton or in a similar package affording an equal degree of protection. GlowShift will return the repaired or replaced Product, freight prepaid, to the Purchaser. GlowShift does not provide Purchasers with temporary replacement units during the warranty period or at any other time. This limited warranty is non-transferrable and will automatically terminate if the original retail consumer purchaser resells the Product or transfers the vehicle in which the Product is installed. An "original retail consumer purchaser" is a person who originally purchases the Product, or a gift recipient of a new Product that is in its original packaging and unopened. This limited warranty is subject to all of the following terms and conditions:

TERMS AND CONDITIONS

- 1. NOTIFICATION OF CLAIMS; WARRANTY SERVICE:** If Purchaser believes that a Product is defective in material or workmanship, written notice with an explanation of the claim shall be given promptly by Purchaser to GlowShift. All warranty claims must be made within the warranty period, and any Products returned to GlowShift must be shipped in accordance with GlowShift's procedures (including use of RMA numbers supplied by GlowShift after notification). The repair or replacement of any Product or part thereof shall not extend the original warranty period. The specific warranty on the repaired part only (not including gauge sensors) shall be in effect for a period of ninety (90) days following the repair or replacement of that part, or the remaining period of the Product warranty, whichever is greater. GlowShift does not provide a warranty on replacement gauge sensors.
- 2. EXCLUSIVE REMEDY; ACCEPTANCE:** Purchaser's exclusive remedy and GlowShift's sole obligation is to supply (or pay for) all labor necessary to repair any Product found to be defective within the repair or replacement fails to remedy the defect. Purchaser's failure to make a claim as provided in paragraph 1 above or continued use of the Product shall constitute an unqualified acceptance of such Product and a waiver by Purchaser of all claims thereto.
- 3. EXCEPTIONS TO LIMITED WARRANTY:** GlowShift shall have no obligation to Purchaser with respect to any Product that is subjected to any of the following: abuse, improper use, negligence, accident, modification, failure to follow the operating procedures outlined in the user's manual, failure to follow the maintenance procedures in the service manual for the Product, attempted repair by non-qualified personnel, operation of the Product outside of the published environmental and electrical parameters, or if the Product's original identification (trademark, serial number) markings have been defaced, altered, or removed. GlowShift excludes from warranty coverage Products sold AS IS and/or WITH ALL FAULTS. GlowShift also excludes from warranty coverage any consumable items such as fuses and batteries. All software and accompanying documentation furnished with, or as part of the Product is furnished "AS IS" (i.e., without any warranty of any kind), except where expressly provided otherwise in any documentation or license agreement furnished with the Product.
- 4. PROOF OF PURCHASE; REGISTRATION:** The Purchaser's dated bill of sale must be retained as evidence of the date of purchase and to establish warranty eligibility. Registration of any Product or of this limited warranty is voluntary, and failure to register will not diminish any rights available under this warranty.

DISCLAIMER OF WARRANTY

EXCEPT FOR THE FOREGOING WARRANTIES, GLOWSHIFT HEREBY DISCLAIMS AND EXCLUDES ALL OTHER WARRANTIES, EXPRESS OR IMPLIED, INCLUDING, BUT NOT LIMITED TO ANY IMPLIED WARRANTIES OF MERCHANTABILITY, FITNESS FOR A PARTICULAR PURPOSE, OR ANY WARRANTY WITH REGARD TO ANY CLAIM OF INFRINGEMENT THAT MAY BE PROVIDED IN SECTION 2-312(3) OF THE UNIFORM COMMERCIAL CODE OR IN ANY OTHER STATE STATUTE.

LIMITATION OF LIABILITY

THE LIABILITY OF GLOWSHIFT, IF ANY, AND PURCHASER'S SOLE AND EXCLUSIVE REMEDY FOR DAMAGES FOR ANY CLAIM OF ANY KIND WHATSOEVER, REGARDLESS OF THE LEGAL THEORY AND WHETHER ARISING IN TORT OR CONTRACT, SHALL NOT BE GREATER THAN THE ACTUAL PURCHASE PRICE OF THE PRODUCT FOR WHICH SUCH CLAIM IS MADE. IN NO EVENT SHALL GLOWSHIFT BE LIABLE TO PURCHASER FOR ANY SPECIAL, INDIRECT, INCIDENTAL, OR CONSEQUENTIAL DAMAGES OF ANY KIND INCLUDING, BUT NOT LIMITED TO, COMPENSATION, REIMBURSEMENT OR DAMAGES ON ACCOUNT OF THE LOSS OF PRESENT OR PROSPECTIVE PROFITS OR FOR ANY OTHER REASON WHATSOEVER.

GOVERNING LAW: This non-transferrable limited warranty shall be governed by the law of the State of New Jersey, U.S.A., and the United States of America, excluding their conflicts of laws principles. The courts of Camden County, New Jersey, shall have the exclusive jurisdiction over any legal action with respect to this warranty.

This limited warranty gives specific legal rights. You may also have other rights that may vary from state to state or from country to country. Some states or countries do not allow the exclusion or limitation of incidental or consequential damages, so the above limitations and exclusions may not apply to you. You are advised to consult applicable state or country laws for a full determination of rights.