

65MM Mechanical Water Temperature Gauge Instructions



The following instructions are for the installation of your Mechanical Water Temperature Gauge. Before you begin, lay out all items and ensure there are no missing parts. If any items are missing, please STOP immediately and contact GlowShift Gauges.

What's Included

- Mechanical Water Temperature Gauge
- Power Harness
- Mounting Bracket

Wiring Schematic

Red: 12v Ignition Switched Source (+)

Orange: 12v Headlight Switched Source (+)

Black: Vehicle/Engine Ground (-)

⚠ WARNING Disconnect negative battery terminal before starting any work on the vehicle.

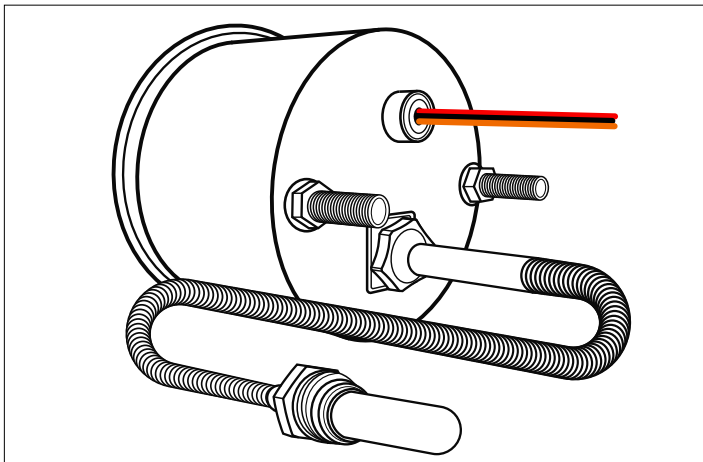

1. There are several different ways to connect a Water Temperature Gauge to your vehicle. In some cases an adapter is needed to adapt the 3/8-18 NPT Sensor Probe.
 - Note:** If you install the sensor probe after the vehicles thermostat, the gauge will not display a reading until the vehicle thermostat has been opened.
 - **Coolant Fluid Port:** Identify a coolant fluid port located on your engine and remove the port plug. Directly install the water temperature sensor to the coolant port. Additional adapters may be required if the coolant port is not threaded to 3/8-18 NPT Sensor Probe.
 - **Stock Sensor Location:** Use a T-fitting to "T" off your stock sensor location. This will allow you to keep your stock sensor installed, while also allowing you to install an aftermarket temperature sensor.
2. Starting with the Mechanical Water Temperature Gauge in the desired location, route the temperature sensor probe through the firewall, and to the desired installation location, be sure to use a grommet. Use Zip Ties to secure the probe from heat and moving parts.

3. To install the Water Temperature Sensor Probe, start by applying Teflon tape to the Water Temperature Sensor Probe threads. Install the 3/8-18 NPT Sensor Probe to your vehicle's system using one of the mentioned methods that will work best for your application.

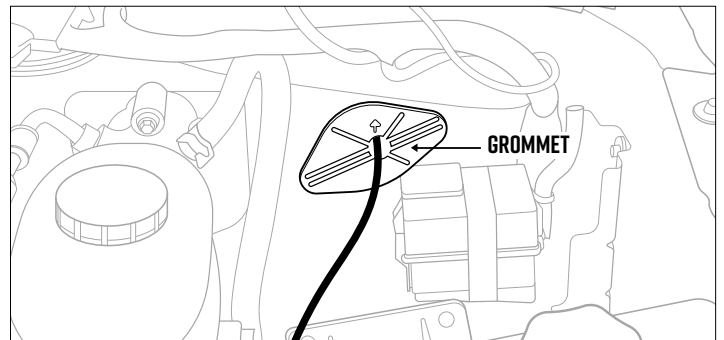

4. Before starting the engine, be sure to refill/replace any coolant lost during the installation process to the manufacturer's specifications.

Gauge Wiring

1. In order to test for power, reconnect the Negative Battery Terminal.
2. It may be necessary to remove Vehicle Trim and/or Kick Panels in order to gain access to the vehicle's Fuse Box.
3. Using a Test Light, locate a Switched 12-Volt Power Source in the vehicle's Fuse Panel that receives 12-Volt power when the ignition is turned on. You can splice into the circuit or use an optional expandable circuit, connect the **Red Wire** of the gauge to the Switched 12-Volt Power Source.

Note: It is required to use an automotive grade 18-20 gauge wire and proper splice connectors when extending any of the power wires.

4. Connect the **Orange Wire** of the gauge to the positive head light switch Power Source using a Splice Connector or Expandable Circuit either in the Fuse Box or the switch itself in order to have the gauge face dim 30% when the headlights are turned on.

Note: Make sure that the connection source is **not** adjustable. If the voltage is reduced when you lower the Dimmer Wheel it could cause the gauge to flash from not having enough voltage.

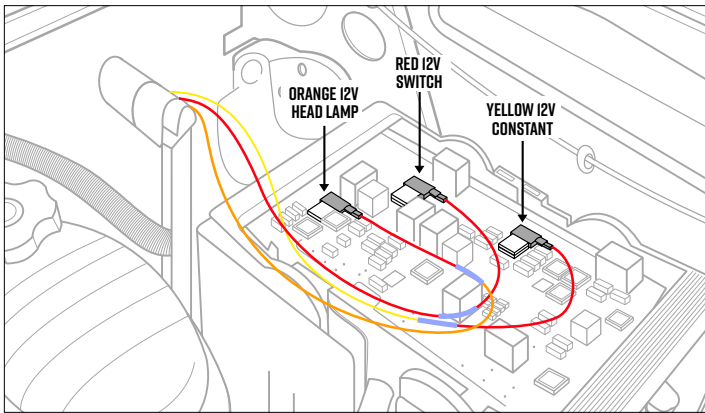

5. Locate a clean, reliable grounding source and connect the **Black Wire** from the gauge.
6. After all wiring is complete, turn the vehicle's key to the "On" position and ensure your gauge illuminate.
7. Reinstall any panels that may have been removed.
8. Turn on the headlights to ensure that the gauge is dimming properly.
9. Start the vehicle and check for leaks.
10. Test drive your vehicle to ensure your gauge is functioning properly.



ONE YEAR NON-TRANSFERRABLE LIMITED WARRANTY & DISCLAIMER

GlowShift Gauges, LLC ("GlowShift") warrants to the original retail consumer purchaser, and not any other purchaser or subsequent owner, that this Product will be free from defects in material or workmanship for a period of **one (1) year** from the purchase date.

For a period of **one (1) year** from the date of purchase, at no charge to the Purchaser, GlowShift will repair or replace this Product if it is determined by GlowShift to be defective. After the warranty period, the Purchaser must pay all charges for parts and labor.

Coverage under this warranty is only valid within the United States, including its territories, as well as in certain other countries. Purchasers should check our website, www.GlowShift.com, to determine the warranty coverage in the countries in which they are located.

GlowShift does **not warrant the installation** of the Product, which is the sole responsibility of the Purchaser. Installation should be done by licensed professionals. Improper installation may cause damage to the Product and any vehicle in which it is installed, and may cause burns and electrical injury to individuals. GlowShift's warranty does not cover any expenses incurred in removing Products that are defective or reinstalling replacement Products in their place.

During the warranty period, to have the Product repaired or replaced, the Purchaser must return the Product, freight prepaid by the Purchaser, to GlowShift (but for customers in the contiguous United States, GlowShift will pay the shipping charges if any Product fails during the first thirty (30) days after purchase). The Product must be returned in its original carton or in a similar package affording an equal degree of protection. GlowShift will return the repaired or replaced Product, freight prepaid, to the Purchaser. GlowShift does not provide Purchasers with temporary replacement units during the warranty period or at any other time.

This limited warranty is nontransferrable and will automatically terminate if the original retail consumer purchaser resells the Product or transfers the vehicle in which the Product is installed. An "original retail consumer purchaser" is a person who originally purchases the Product, or a gift recipient of a new Product that is in its original packaging and unopened.

This limited warranty is subject to all of the following terms and conditions:

TERMS & CONDITIONS

- 1. NOTIFICATION OF CLAIMS; WARRANTY SERVICE:** If Purchaser believes that a Product is defective in material or workmanship, written notice with an explanation of the claim shall be given promptly by Purchaser to GlowShift. All warranty claims must be made within the warranty period, and any Products returned to GlowShift must be shipped in accordance with GlowShift's procedures (including use of RMA numbers supplied by GlowShift after notification). The repair or replacement of any Product or part thereof shall not extend the original warranty period. The specific warranty on the repaired part only (not including gauge sensors) shall be in effect for a period of ninety (90) days following the repair or replacement of that part, or the remaining period of the Product warranty, whichever is greater. GlowShift does not provide a warranty on replacement gauge sensors.
- 2. EXCLUSIVE REMEDY; ACCEPTANCE:** Purchaser's exclusive remedy and GlowShift's sole obligation is to supply (or pay for) all labor necessary to repair any Product found to be defective within the repair or replacement fails to remedy the defect. Purchaser's failure to make a claim as provided in paragraph 1 above or continued use of the Product shall constitute an unqualified acceptance of such Product and a waiver by Purchaser of all claims thereto.
- 3. EXCEPTIONS TO LIMITED WARRANTY:** GlowShift shall have no obligation to Purchaser with respect to any Product that is subjected to any of the following: abuse, improper use, negligence, accident, modification, failure to follow the operating procedures outlined in the user's manual, failure to follow the maintenance procedures in the service manual for the Product, attempted repair by nonqualified personnel, operation of the Product outside of the published environmental and electrical parameters, or if the Product's original identification (trademark, serial number) markings have been defaced, altered, or removed. GlowShift excludes from warranty coverage Products sold AS IS and/or WITH ALL FAULTS. GlowShift also excludes from warranty coverage any consumable items such as fuses and batteries.

All software and accompanying documentation furnished with, or as part of the Product is furnished "AS IS" (i.e., without any warranty of any kind), except where expressly provided otherwise in any documentation or license agreement furnished with the Product.
- 4. PROOF OF PURCHASE; REGISTRATION:** The Purchaser's dated bill of sale must be retained as evidence of the date of purchase and to establish warranty eligibility. Registration of any Product or of this limited warranty is voluntary, and failure to register will not diminish any rights available under this warranty.

DISCLAIMER OF WARRANTY

EXCEPT FOR THE FOREGOING WARRANTIES, GLOWSHIFT HEREBY DISCLAIMS AND EXCLUDES ALL OTHER WARRANTIES, EXPRESS OR IMPLIED, INCLUDING, BUT NOT LIMITED TO ANY IMPLIED WARRANTIES OF MERCHANTABILITY, FITNESS FOR A PARTICULAR PURPOSE, OR ANY WARRANTY WITH REGARD TO ANY CLAIM OF INFRINGEMENT THAT MAY BE PROVIDED IN SECTION 2312(3) OF THE UNIFORM COMMERCIAL CODE OR IN ANY OTHER STATE STATUTE.

LIMITATION OF LIABILITY

THE LIABILITY OF GLOWSHIFT, IF ANY, AND PURCHASER'S SOLE AND EXCLUSIVE REMEDY FOR DAMAGES FOR ANY CLAIM OF ANY KIND WHATSOEVER, REGARDLESS OF THE LEGAL THEORY AND WHETHER ARISING IN TORT OR CONTRACT, SHALL NOT BE GREATER THAN THE ACTUAL PURCHASE PRICE OF THE PRODUCT FOR WHICH SUCH CLAIM IS MADE. IN NO EVENT SHALL GLOWSHIFT BE LIABLE TO PURCHASER FOR ANY SPECIAL, INDIRECT, INCIDENTAL, OR CONSEQUENTIAL DAMAGES OF ANY KIND INCLUDING, BUT NOT LIMITED TO, COMPENSATION, REIMBURSEMENT OR DAMAGES ON ACCOUNT OF THE LOSS OF PRESENT OR PROSPECTIVE PROFITS OR FOR ANY OTHER REASON WHATSOEVER.

GOVERNING LAW: This nontransferrable limited warranty shall be governed by the law of the State of New Jersey, U.S.A., and the United States of America, excluding their conflicts of laws principles. The courts of Camden County, New Jersey, shall have the exclusive jurisdiction over any legal action with respect to this warranty.

This limited warranty gives specific legal rights. You may also have other rights that may vary from state to state or from country to country. Some states or countries do not allow the exclusion or limitation of incidental or consequential damages, so the above limitations and exclusions may not apply to you. You are advised to consult applicable state or country laws for a full determination of rights.