

## Elite 10 Color Series - 120°F to 300°F – Transmission Temperature Gauge

For Product Numbers: GS-ET12

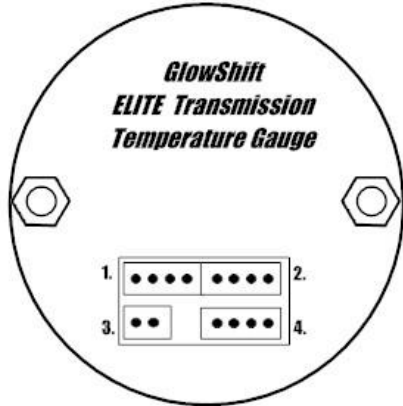

1. Power Wire Harness
2. Power Wire Harness
3. Warning Light (optional)
4. Sensor Wire Harness

### Power Wire Harness

(Slot 1 or 2)



Black  
Red  
White  
Orange

### Sensor Wire Harness

(Slot 4)

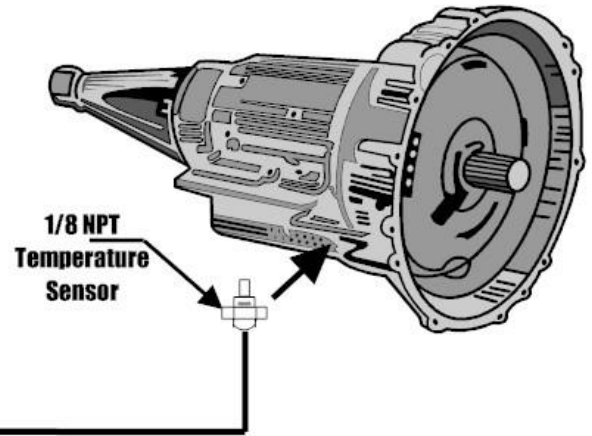
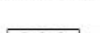

### Power Wire Harness Color Code

**Black:** Vehicle / Engine Ground (-)

**Red:** 12v Constant (un-switched) Source (+)

**Orange:** 12v Dimmer (switched) Source (+) (optional)

**White:** 12v Ignition (switched) Source (+)

**Daisy Chain Power Connections:** Simply plug one end of the included daisy chain harness into the first gauge that is connected to the power and ground sources. Next, plug the other end into the second gauge and repeat for the third & fourth. Max 4 gauges.

1. Disconnect the negative battery cable.

2. Using automotive grade wiring (18 gauge), connect the **red wire** to a positive 12 volt constant (un-switched) source, either directly to the battery or to a fuse panel on the vehicle.

- *If wiring to an un-fused source, install a 3 amp fuse inline within 20 inches of the sources connection. You may obtain an optional "add a circuit" accessory. This component easily fits into your fuse panel and provides an additional fused power wire for accessories such as gauges. This is available at [www.GlowShift.com](http://www.GlowShift.com) or a local auto parts store.*

3. Using automotive grade wiring (18 gauge), connect the **white wire** to a positive 12 volt ignition (switched) source. It may be connected to the fuse panel, an accessory wire, or any positive 12 volt source that turns on and off with the ignition switch of the vehicle.

4. (Optional) The dimming feature of the Elite Series decreases the brightness of the gauge face by 30%. Using automotive grade wiring (18 gauge), connect the **orange wire** to a positive 12 volt switched source. The most common installation is to splice and connect to the 12 volt positive headlight source.

5. Using automotive grade wiring (18 gauge), connect the **black wire** from the gauge to any good (unpainted) ground connection. You may also route a wire directly to the negative side of the vehicle's battery.

6. There are two common types of transmission temperature sender unit installations:

- **Transmission Test Port:** Most vehicle transmissions come equipped with a test port location. This may be located on either the driver or passenger sides of the transmission near the transmission oil pan. The bolt in this port should be removed and the sensor fitted in its place. Confirm port and thread size with your vehicle dealer or owner's manual.
- **Replace Stock Sensor:** The second is to remove the stock sender unit for the warning light on your dash. In most vehicles this sensor is not connected to your PCM and removing it will not affect anything. YOU MUST confirm this with your dealer or owner's manual before removing and replacing the sensor with the GlowShift unit.

7. Route the **temperature sensor wire harness** from the back of the gauge (**slot #4**) through the firewall, engine bay and to the sensor. Next, couple and secure the **sensor wire harness** to the temperature sensor.

- *Be sure to use a grommet when routing wires through the firewall to protect them from stripping and damage.*

8. Reconnect the negative battery cable.

- *You may use the supplied daisy chain power wire harness to connect and power multiple GlowShift Elite Gauges from one set of power supply wires. (MAX 4 GAUGES)*

**Operating Instructions**

**1. 10-Color Mode:**

- 1) Press the **COLOR** button to cycle between the colors.
- 2) The sequence of display colors are: Blue – Green – Red – Yellow – White – Light Blue – Purple – Pink – Orange – Amber. After Amber there are two (2) automatic color changing functions on the gauge that begin with the color Blue. They are the 10 Color Cycle Mode and the 10 Color Slow Fade Mode.

**2. Peak Mode:**

- 1) Press the **SET** button to recall the peak value and enter into the peak setting mode. The word PEAK will turn blue when you are in the peak setting mode
- 2) When the peak value is displayed, press the **COLOR** button to clear the previous peak value. When the Peak Blue LED is not flashing, the gauge is operating in normal mode.

**3. High-Warning Mode:**

- 1) Hold the **COLOR** button for 5 seconds to enter into the High-warning setting mode.
- 2) When the needle is flashing and the warning light is on, you can now program the High-Warning Mode Value. Pressing the **COLOR** button will move the needle clockwise while pressing the **SET** button will move the needle counter-clockwise.
- 3) Holding either the **COLOR** button or the **SET** button will move the needle in major increments in the buttons respective direction.
- 4) After 5 seconds of no button activity, the gauge will return to its normal operating mode.
- 5) To turn the warning sound on for this mode, turn the gauge off. While holding the **COLOR** button, turn on the gauge until you hear a single beeping sound. Repeat to turn off.

**4. Low-Warning Mode:**

- 1) Hold the **SET** button for 5 seconds to enter into the Low-warning setting mode.
- 2) When the needle and warning light are flashing, you can now program the Low-Warning Mode Value. Pressing the **COLOR** button will move the needle clockwise while pressing the **SET** button will move the needle counter-clockwise.
- 3) Holding either the **COLOR** button or the **SET** button will move the needle in major increments in the buttons respective direction.
- 4) After 5 seconds of no button activity, the gauge will return to its normal operating mode.
- 5) To turn the warning sound on for this mode, turn the gauge off. While holding the **SET** button, turn on the gauge until you hear a single beeping sound. Repeat to turn off.

**5. Key Sound Mode:**

- 1) To hear the key sound when either button is pressed, turn the gauge off.
- 2) Hold the **COLOR** and **SET** buttons at the same time and then turn on the gauge until you hear two beeping sounds. The Key Sound Mode is now activated.
- 3) Holding the **COLOR** and **SET** buttons at the same time and then turning off the gauge will deactivate this setting.

*Additional Installation Information & Material Requirements*

- **GlowShift Gauges Approved Conductor Wires:** Successfully installing GlowShift Gauges may require lengths of wire (sizes and quantity depend on vehicle, gauge type, gauge location and / or sensor location). For correct and proper GlowShift Gauge installation and operation, the use of 18 Gauge (wire diameter) automotive grade conductor wire with sheathing is recommended for one or more gauges per vehicle. When installing and routing wires from the engine compartment, to inside the vehicle cabin, always employ the use of a rubber grommet. This will prevent and deter the stripping of power supply and / or sensor wires that is necessary to deliver vital statistics about your engine to your GlowShift engine monitoring instruments. Never use wire nuts to fasten or bound vehicle / gauge or sensor wiring. Always use securing crimp connectors or solder individual wire junctions together for optimum gauge installation and operation.
- **GlowShift Gauges Approved Installation Accessories:** GlowShift Gauges may require the installer or user to provide additional products, accessories or adapters for the correct installation and operation of a gauge or sensor, as per the GlowShift Installation Instructions. When installing and routing hoses to or from the engine compartment, to inside the vehicle cabin, always employ the use of a rubber grommet. This will prevent and deter the stretching or pinching of hoses that is necessary to deliver vital statistics about your engine to your GlowShift engine monitoring instruments.
- **GlowShift Gauges Installation Instructions:** Installation documents are solely to provide a guide for individuals that are mechanically and electronically able to install products. If you are unsure about the correct procedure of installation for a product or device, you should consult a professional mechanic or an Authorized GlowShift Installer.

---

*Limited Warranty and Disclaimer*

GlowShift Gauges, LLC. products come with a one year limited warranty on the internal parts of the product. This warranty starts from the date of purchase. GlowShift Gauges, LLC. will replace or repair any qualifying defective product received by the company before the end of the warranty period. Installation of this product must be performed by a licensed professional. Should the failure of the product be the result of damage occurring as a result of improper installation, alteration of the product or an act or omission on the part of the consumer, this warranty is void. GlowShift Gauges, LLC. shall not be responsible for any consequential damages which arise from the use and/or installation of the product. If the kit is installed in any manner other than specified, GlowShift Gauges, LLC. reserves the right to deny any warranty claims at the discretion of the technical support department. The one year warranty is not transferable and is valid for up to one year from the original date of purchase. Any product return must include the original packaging, a statement of the alleged defect and an RMA number must be provided. All RMA numbers are valid for 14 days from issued date. Upon receipt of the returned product, the company will test the product for defect. If the results of the testing do not support the warranty claim, do not reveal any defect or indicate consumer negligence in the installation and handling of the product, then the product will be returned to you and you will be charged a reshipping fee. If the product is returned from an address within the continental United States, within the first 14 days after purchase, and is found to be defective, GlowShift Gauges, LLC. will cover the cost of the return shipping with an emailed return label. This offer is only valid for the continental US. All international shipping, customs fees and/or duty charges are solely the responsibility of the consumer.

---

*Additional Disclaimer Terms*

- Improper installation of electricity-using products may cause damage to any vehicle or device to which the improperly handled or installed device is attached.
- Improperly installed product may cause electrical injury to persons.
- It is recommended that the device be installed by a licensed professional.
- GlowShift Gauges, LLC. assumes no liability for the installation of the product.
- Warranty or liability will not exceed the product purchase price which shall be the buyer's sole and exclusive remedy.

[THERE ARE NO WARRANTIES WHICH EXTEND BEYOND THE WARRANTIES DESCRIBED ON THE FACE HEREOF INCLUDING ANY IMPLIED WARRANTIES OF MERCHANTABILITY OR FITNESS FOR A PARTICULAR PURPOSE. (GLOWSHIFT GAUGES, LLC. AT IT'S DISCRETION, MAY PROVIDE REMEDY OF RETURN OF PURCHASE PRICE OR REPAIR OR REPLACEMENT OF DEFECTIVE PRODUCT AS BUYERS SOLE AND EXCLUSIVE REMEDY.)

GlowShift Gauges, LLC. - 150 Cooper Road - Suite B-6 West Berlin, NJ 08091

**Effective 6/2010**