

## Digital Series - Wideband Air/Fuel Ratio Gauge with Data Logging Output

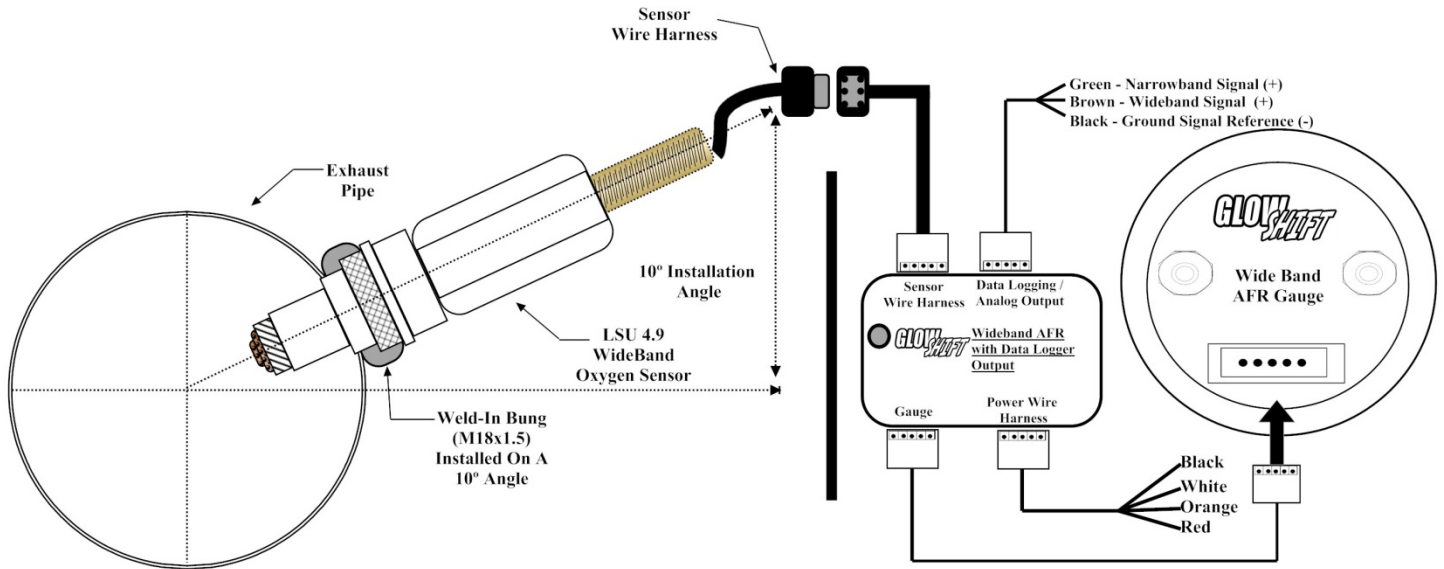

**Wire Color Code**

Black	Vehicle Ground ( - )	Red	12v Constant (un-switched) Source (+)
White	12v Ignition (switched) Source (+)	Orange	12v Head Lamp (switched) Source (+)

1. Disconnect the negative battery cable.
2. Mount the controller inside the vehicle away from heat, water, moisture, dirt and all moving parts, in an easily accessible location. This allows for the unit to be accessible should calibration need to be performed.
3. Using automotive grade wiring (18 gauge), connect the **red wire** to a positive 12 volt constant (un-switched) source either directly to the battery or to a fuse panel on the vehicle. If wiring to an un-fused source, install a 3 amp fuse inline within 20 inches of the sources connection.
  - *If wiring to an un-fused source, install a 3 amp fuse inline within 20 inches of the sources connection. You may obtain an optional “add a circuit” accessory. This component easily fits into your fuse panel and provides an additional fused power wire for accessories such as gauges. This is available at [www.GlowShift.com](http://www.GlowShift.com) or a local auto parts store.*
4. The **white wire** should be connected to a positive 12 volt ignition (switched) source. It may be connected to the fuse panel, an accessory wire, or any positive 12 volt source that turns on and off with the ignition.
5. Connect the **black wire** to any good (unpainted) ground connection. You may also route a wire directly to the negative side of the vehicle’s battery.
6. The **orange wire** should be connected to a positive 12 volt switched source (head lamp). This controls the dimmer function to dim the gauge brightness by 30%. This step is optional.
7. Install the provided LSU 4.9 Sensor by welding the matching exhaust bung to the exhaust pipe.
  - Make sure the location of the bung is no less than a **minimum of 18 inches** after the exhaust ports, but **before the catalytic converter**. **The bung must be positioned in such a way that the sensor is at a minimum of 10 degrees from a horizontal position with the electrical connection up to prevent a collection of liquid at the element during the warm up phase. SEEDIAGRAMABOVE.**
8. Next, route and secure the sensor wire harness from the sensor into the vehicle, close to the controller’s location. Be sure to use a grommet when routing the wires through the firewall to protect them from stripping.
9. Reconnect the negative battery cable.
  - *Be sure all of your wiring is correct for proper gauge operation.*

# GLOW SHIFT<sup>®</sup> INSTALLATION INSTRUCTIONS

PERFORMANCE GAUGES & PODS

Tech Support  
 856-768-8300 EXT 2  
 TechSupport@GlowShiftGauges.com

## Calibration Schedule

To obtain the most accurate results from your gauge, please follow the calibration schedule pre and post installation:

### A. For Everyday Driven Vehicles

- Calibrate after installation.
- Calibrate again, after 3 months of use.
- Calibrate twice a year or every 10,000 miles (whichever comes first).

### B. For Race Vehicles

- Calibrate after installation.
- Calibrate once per race weekend.

### C. Dynamometer Use

- Calibrate after installation.
- Calibrate every 2-3 days, depending on the amount of usage.

## Functions:

1. Prior to operation, the sensor must warm up for 30 seconds. This is a mandatory process every time the gauge and sensor are powered from a cold vehicle start. The LED display will show a scrolling graphic until the warm up phase is complete.
2. If necessary you may perform a manual calibration by pressing the button on the controller for 3 seconds, to initialize a controller /sensor calibration sequence. The LED display on the gauge will show a [2] until the calibrating process is over.
3. If the LED display on the gauge shows a [3] then there is a sensor error detected. Check and confirm the connection of the sensor and wire harness to and from the controller unit. If the connections are secure and in place, press the button on the controller for 8 seconds to reset the controller to the original factory settings. The LED display will show a [2] and then a [4]. After this the factory settings are programmed and restored to your controller. If your display shows a [3] again, your sensor may be defective.

**Remember:** If you replace or change your sensor you must follow the schedule as if it were a new installation.

**Digital Display Read Out:** This gauge is equipped with a 3 digit A/F Ratio display unit:

This displays range is between 10 ~ 20 AFR accurate with-in one (1) decimal place (ex 14.7 AFR).

If the AFR is below 10 or higher than 20 for more than 3 seconds the digital display will flash while showing the AFR.

## Data Logging Output:

Offers two analog outputs for monitoring and capturing Air / Fuel Ratio using a third party data logging device (sold separately).

Wire Color	Function	Connection	Signal Voltage
Green	Provides the positive (+) analog NARROWBAND voltage output signals.	Data Logger (+)	0– 1 volts
Brown	Provides the positive (+) analog WIDEBAND voltage output signals.	Data Logger (+)	0 – 5 volts
Black	Provides the negative (-) ground reference for both analog NARROWBAND & WIDEBAND voltage output signals.	Data Logger (-)	Ground

## Warranty Notice:

The Oxygen Sensor included with this gauge is not manufactured by GlowShift Gauges, LLC. Therefore it is not covered under warranty.

## Additional Installation Information & Material Requirements

- **GlowShift Gauges Approved Conductor Wires:** Successfully installing GlowShift Gauges may require lengths of wire (sizes and quantity depend on vehicle, gauge type, gauge location and / or sensor location). For correct and proper GlowShift Gauge installation and operation, the use of 18 Gauge (wire diameter) automotive grade conductor wire with sheathing is recommended for one or more gauges per vehicle. When installing and routing wires from the engine compartment, to inside the vehicle cabin, always employ the use of a rubber grommet. This will prevent and deter the stripping of power supply and / or sensor wires that is necessary to deliver vital statistics about your engine to your GlowShift engine monitoring instruments. Never use wire nuts to fasten or bound vehicle / gauge or sensor wiring. Always use securing crimp connectors or solder individual wire junctions together for optimum gauge installation and operation.
- **GlowShift Gauges Approved Installation Accessories:** GlowShift Gauges may require the installer or user to provide additional products, accessories or adapters for the correct installation and operation of a gauge or sensor, as per the GlowShift Installation Instructions. When installing and routing hoses to or from the engine compartment, to inside the vehicle cabin, always employ the use of a rubber grommet. This will prevent and deter the stretching or pinching of hoses that is necessary to deliver vital statistics about your engine to your GlowShift engine monitoring instruments.
- **GlowShift Gauges Installation Instructions:** Installation documents are solely to provide a guide for individuals that are mechanically and electronically able to install products. If you are unsure about the correct procedure of installation for a product or device, you should consult a professional mechanic or an Authorized GlowShift Installer.

# **GLOW SHIFT®** *INSTALLATION INSTRUCTIONS*

**PERFORMANCE GAUGES & PODS**

**Tech Support**  
**856-768-8300 EXT 2**  
**TechSupport@GlowShiftGauges.com**

## *Limited Warranty and Disclaimer*

GlowShift Gauges, LLC. products come with a one year limited warranty on the internal parts of the product. This warranty starts from the date of purchase. GlowShift Gauges, LLC. will replace or repair any qualifying defective product received by the company before the end of the warranty period. Installation of this product must be performed by a licensed professional. Should the failure of the product be the result of damage occurring as a result of improper installation, alteration of the product or an act or omission on the part of the consumer, this warranty is void. GlowShift Gauges, LLC. shall not be responsible for any consequential damages which arise from the use and/or installation of the product. If the kit is installed in any manner other than specified, GlowShift Gauges, LLC. reserves the right to deny any warranty claims at the discretion of the technical support department. The one year warranty is not transferable and is valid for up to one year from the original date of purchase. Any product return must include the original packaging, a statement of the alleged defect and an RMA number must be provided. All RMA numbers are valid for 14 days from issued date. Upon receipt of the returned product, the company will test the product for defect. If the results of the testing do not support the warranty claim, do not reveal any defect or indicate consumer negligence in the installation and handling of the product, then the product will be returned to you and you will be charged a reshipping fee. If the product is returned from an address within the continental United States, within the first 14 days after purchase, and is found to be defective, GlowShift Gauges, LLC. will cover the cost of the return shipping with an emailed return label. This offer is only valid for the continental US. All international shipping, customs fees and/or duty charges are solely the responsibility of the consumer.

---

## *Additional Disclaimer Terms*

- Improper installation of electricity-using products may cause damage to any vehicle or device to which the improperly handled or installed device is attached.
- Improperly installed product may cause electrical injury to persons.
- It is recommended that the device be installed by a licensed professional.
- GlowShift Gauges, LLC. assumes no liability for the installation of the product.
- Warranty or liability will not exceed the product purchase price which shall be the buyer's sole and exclusive remedy.

[THERE ARE NO WARRANTIES WHICH EXTEND BEYOND THE WARRANTIES DESCRIBED ON THE FACE HEREOF INCLUDING ANY IMPLIED WARRANTIES OF MERCHANTABILITY OR FITNESS FOR A PARTICULAR PURPOSE. (GLOWSHIFT GAUGES, LLC. AT IT'S DISCRETION, MAY PROVIDE REMEDY OF RETURN OF PURCHASE PRICE OR REPAIR OR REPLACEMENT OF DEFECTIVE PRODUCT AS BUYERS SOLE AND EXCLUSIVE REMEDY.)

GlowShift Gauges, LLC. - 150 Cooper Road - Suite B-6 West Berlin, NJ 08091

**Effective 6/2010**